

MAXIM

Low-Noise, 5.5V-Input, PWM Step-Down Regulator

MAX1692

General Description

The MAX1692 is a low-noise, pulse-width-modulated (PWM), DC-DC step-down converter. It powers logic and transmitters in small wireless systems such as cellular phones, communicating PDAs, and handy-terminals. The device features an internal synchronous rectifier for high efficiency; it requires no external Schottky diode. Excellent noise characteristics and fixed-frequency operation provide easy post-filtering. The MAX1692 is ideally suited for Li-Ion battery applications. It is also useful for +3V or +5V fixed input applications.

The device operates in one of four modes. Forced PWM mode operates at a fixed frequency regardless of the load. Synchronizable PWM mode allows an external switching frequency to control and minimize harmonics. Idle Mode™ (PWM/PFM) extends battery life by switching to a PFM pulse-skipping mode during light loads. Shutdown mode places the device in standby, reducing quiescent supply current to under 0.1µA.

The MAX1692 can deliver over 600mA. The output voltage can be adjusted from 1.25V to V_{IN} with the input range of +2.7V to +5.5V. Other features of the MAX1692 include high efficiency, low dropout voltage, and a 1.2%-accurate 1.25V reference. It is available in a space-saving 10-pin µMAX package with a height of only 1.11mm.

Applications

Cellular Phones	CPU I/O Supplies
Cordless Phones	Notebook Chipset Supplies
PDAs and Handy-Terminals	Battery-Operated Devices (1 Li-Ion or 3 NiMH/NiCd)

Features

- ◆ +2.7V to +5.5V Input Range
- ◆ Adjustable Output from 1.25V to V_{IN}
- ◆ 600mA Guaranteed Output Current
- ◆ 95% Efficiency
- ◆ No Schottky Diode Required
- ◆ 85µA Quiescent Current
- ◆ 100% Duty Cycle in Dropout
- ◆ 750kHz Fixed-Frequency PWM Operation
- ◆ Synchronizable Switching Frequency
- ◆ Accurate Reference: 1.25V ($\pm 1.2\%$)
- ◆ Small 10-Pin µMAX Package

Ordering Information

PART	TEMP. RANGE	PIN-PACKAGE
MAX1692EUB	-40°C to +85°C	10 µMAX

Pin Configuration

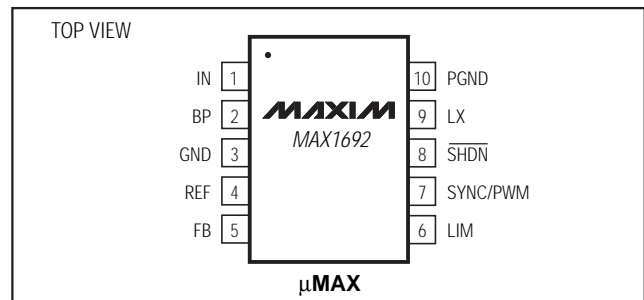

Typical Operating Circuit

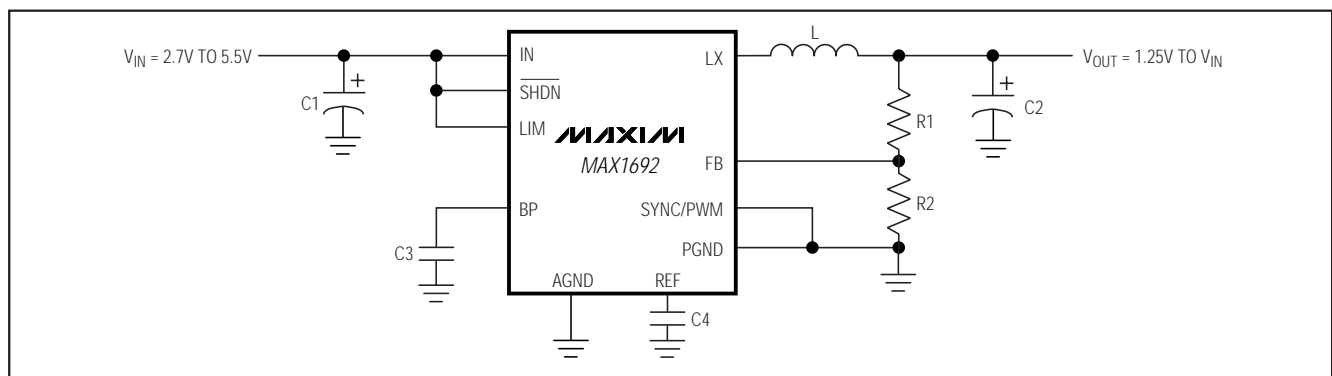

Idle Mode is a trademark of Maxim Integrated Products.

MAXIM

Maxim Integrated Products 1

For free samples & the latest literature: <http://www.maxim-ic.com>, or phone 1-800-998-8800.
For small orders, phone 1-800-835-8769.

Low-Noise, 5.5V-Input, PWM Step-Down Regulator

ABSOLUTE MAXIMUM RATINGS

IN, BP, $\overline{\text{SHDN}}$, SYNC/PWM, LIM to GND	-0.3V to +6V
BP to IN	-0.3V to +0.3V
PGND to GND	-0.3V to +0.3V
LX to PGND	-0.3V to ($V_{\text{IN}} + 0.3\text{V}$)
FB, REF to GND	-0.3V to ($V_{\text{BP}} + 0.3\text{V}$)
Reference Current	$\pm 1\text{mA}$
LX Peak Current (internally limited)	1.6A

Continuous Power Dissipation ($T_{\text{A}} = +70^{\circ}\text{C}$)	
10-Pin μMAX (derate 5.6mW/ $^{\circ}\text{C}$ above $+70^{\circ}\text{C}$)	444mW
Operating Temperature Range	-40°C to $+85^{\circ}\text{C}$
Maximum Junction Temperature	$+150^{\circ}\text{C}$
Storage Temperature Range	-65°C to $+160^{\circ}\text{C}$
Lead Temperature (soldering, 10sec)	$+300^{\circ}\text{C}$

Stresses beyond those listed under "Absolute Maximum Ratings" may cause permanent damage to the device. These are stress ratings only, and functional operation of the device at these or any other conditions beyond those indicated in the operational sections of the specifications is not implied. Exposure to absolute maximum rating conditions for extended periods may affect device reliability.

ELECTRICAL CHARACTERISTICS

($V_{\text{IN}} = +3.6\text{V}$, SYNC/PWM = GND, $V_{\text{LIM}} = 3.6\text{V}$, $\overline{\text{SHDN}} = \text{IN}$, circuit of Figure 2; $T_{\text{A}} = 0^{\circ}\text{C}$ to $+85^{\circ}\text{C}$, unless otherwise noted. Typical values are at $T_{\text{A}} = +25^{\circ}\text{C}$.)

PARAMETER	SYMBOL	CONDITIONS	MIN	TYP	MAX	UNITS
Input Voltage Range	V_{IN}		2.7		5.5	V
Output Voltage	V_{OUT}	FB = OUT, $V_{\text{IN}} = V_{\text{LIM}} = 2.7\text{V}$ to 5.5V , $I_{\text{OUT}} = 0$	1.223	1.249	1.275	V
		FB = OUT, $V_{\text{IN}} = 2.7\text{V}$ to 5.5V , $I_{\text{OUT}} = 0$ to 600mA , LIM = IN or $I_{\text{OUT}} = 0$ to 250mA , LIM = GND	1.190	1.232	1.275	
Output Adjustment Range		(Note 1)	V_{REF}		V_{IN}	V
Feedback Voltage	V_{FB}	FB = OUT, $V_{\text{IN}} = V_{\text{LIM}} = 5.5\text{V}$, $I_{\text{OUT}} = 0$ (duty cycle = 23%) (Note 2)	1.223	1.249	1.275	V
Line Regulation		Duty cycle = 100% to 23%		+1		%
Load Regulation		$I_{\text{OUT}} = 0$ to 600mA , LIM = IN or $I_{\text{OUT}} = 0$ to 250mA , LIM = GND		-1.3		%
FB Input Current	I_{FB}	$V_{\text{FB}} = 1.4\text{V}$	-50	0.01	50	nA
P-Channel On-Resistance	PRDS(ON)	$I_{\text{LX}} = 180\text{mA}$	$V_{\text{IN}} = 3.6\text{V}$	0.3	0.65	Ω
			$V_{\text{IN}} = 2.7\text{V}$	0.4		
N-Channel On-Resistance	NRDS(ON)	$I_{\text{LX}} = 180\text{mA}$	$V_{\text{IN}} = 3.6\text{V}$	0.4	0.8	Ω
			$V_{\text{IN}} = 2.7\text{V}$	0.5		
P-Channel Current-Limit Threshold		LIM = GND	0.35	0.6	0.85	A
		LIM = IN	0.75	1.2	1.55	
N-Channel Current-Limit Threshold		$V_{\text{FB}} = 1.4\text{V}$	-450	-850	-1600	mA
		SYNC/PWM = IN, FB = REF	0	50	100	
Pulse-Skipping Current-Limit Threshold			80	120	160	mA
Quiescent Current		SYNC/PWM = GND, $V_{\text{FB}} = 1.4\text{V}$, LX unconnected		85	140	μA
Shutdown Supply Current		$\overline{\text{SHDN}} = \text{LX} = \text{GND}$, includes LX leakage current		0.1	10	μA
LX Leakage Current		$V_{\text{IN}} = 5.5\text{V}$, $V_{\text{LX}} = 0$ or 5.5V	-20	0.1	20	μA
Oscillator Frequency	f_{OSC}		650	750	830	kHz
SYNC Capture Range			500		1000	kHz
Maximum Duty Cycle	dutyMAX		100			%
Minimum Duty Cycle	dutyMIN				22	%
Reference Output Voltage	V_{REF}	$I_{\text{REF}} = 0$	1.235	1.250	1.265	V

Low-Noise, 5.5V-Input, PWM Step-Down Regulator

MAX1692

ELECTRICAL CHARACTERISTICS (continued)

($V_{IN} = +3.6V$, SYNC/PWM = GND, $V_{LIM} = 3.6V$, $\overline{SHDN} = IN$, circuit of Figure 2; $T_A = 0^\circ C$ to $+85^\circ C$, unless otherwise noted. Typical values are at $T_A = +25^\circ C$.)

PARAMETER	SYMBOL	CONDITIONS	MIN	TYP	MAX	UNITS
Reference Load Regulation		$0 \leq I_{REF} \leq 50\mu A$		3	15	mV
Undervoltage Lockout Threshold	UVLO	V_{IN} rising, typical hysteresis is 85mV	2.3	2.4	2.5	V
Logic Input High	V_{IH}	\overline{SHDN} , SYNC/PWM, LIM	2			V
Logic Input Low	V_{IL}	\overline{SHDN} , SYNC/PWM, LIM			0.4	V
Logic Input Current		\overline{SHDN} , SYNC/PWM, LIM	-1	0.1	1	μA
SYNC/PWM Minimum Pulse Width		High or low	500			ns

ELECTRICAL CHARACTERISTICS

($V_{IN} = +3.6V$, SYNC/PWM = GND, $V_{LIM} = 3.6V$, $\overline{SHDN} = IN$, circuit of Figure 2, $T_A = -40^\circ C$ to $+85^\circ C$, unless otherwise noted.) (Note 3)

PARAMETER	SYMBOL	CONDITIONS	MIN	MAX	UNITS
Input Voltage Range	V_{IN}		2.7	5.5	V
Output Voltage	V_{OUT}	FB = OUT, $V_{IN} = V_{LIM} = 2.7V$ to 5.5V, $I_{OUT} = 0$	1.213	1.285	V
		FB = OUT, $V_{IN} = 2.7V$ to 5.5V, $I_{OUT} = 0$ to 600mA, LIM = IN or $I_{OUT} = 0$ to 250mA, LIM = GND	1.185	1.285	
Output Adjustment Range		(Note 1)	REF	V_{IN}	V
Feedback Voltage	V_{FB}	FB = OUT, $V_{IN} = V_{LIM} = 5.5V$, $I_{OUT} = 0$ (duty cycle = 23%) (Note 2)	1.213	1.285	V
FB Input Current	I_{FB}	$V_{FB} = 1.4V$	-50	50	nA
P-Channel Current-Limit Threshold		LIM = GND	0.3	0.9	A
		LIM = IN	0.7	1.6	
N-Channel Current-Limit Threshold		SYNC/PWM = IN, FB = REF	-15	110	mA
Quiescent Current		SYNC/PWM = GND, LX = unconnected, $V_{FB} = 1.4V$		140	μA
Shutdown Supply Current		$\overline{SHDN} = LX = GND$, includes LX leakage current		10	μA
Oscillator Frequency	f_{OSC}		630	840	kHz
Reference Output Voltage	V_{REF}	$I_{REF} = 0$	1.230	1.268	V
Undervoltage Lockout Threshold	UVLO	V_{IN} rising, typical hysteresis is 85mV	2.3	2.5	V
Logic Input High	V_{IH}	\overline{SHDN} , SYNC/PWM, LIM	2		V
Logic Input Low	V_{IL}	\overline{SHDN} , SYNC/PWM, LIM		0.4	V
Logic Input Current		\overline{SHDN} , SYNC/PWM, LIM	-1	1	μA

Note 1: Guaranteed by minimum and maximum duty-factor tests.

Note 2: The following equation can be used to calculate FB accuracy for output voltages other than 1.232V: (see Feedback Voltage vs. Load Current)

$$V_{FB} = V_{FB}(\text{NOMINAL}) - (\text{Line Reg})(V_{OUT} / V_{IN} - 0.23) / 0.77 - (|\text{Load Reg}|)(I_{OUT} + 0.5 \cdot I_{RIPPLE}) / I_{MAX}$$

where: Line Reg = the line regulation

Load Reg = the load regulation

$$I_{RIPPLE} = (1 - V_{OUT} / V_{IN}) \cdot V_{OUT} / (f_{OSC} \cdot L) \text{ where } L \text{ is the inductor value}$$

$$I_{MAX} = 250\text{mA (LIM = GND) or } 600\text{mA (LIM = IN)}$$

Note 3: Specifications to $-40^\circ C$ are guaranteed by design, not production tested.

Low-Noise, 5.5V-Input, PWM Step-Down Regulator

Typical Operating Characteristics

(SYNC/PWM = GND, circuit of Figure 2, L = Sumida CD43-100, $T_A = +25^\circ\text{C}$, unless otherwise noted.)

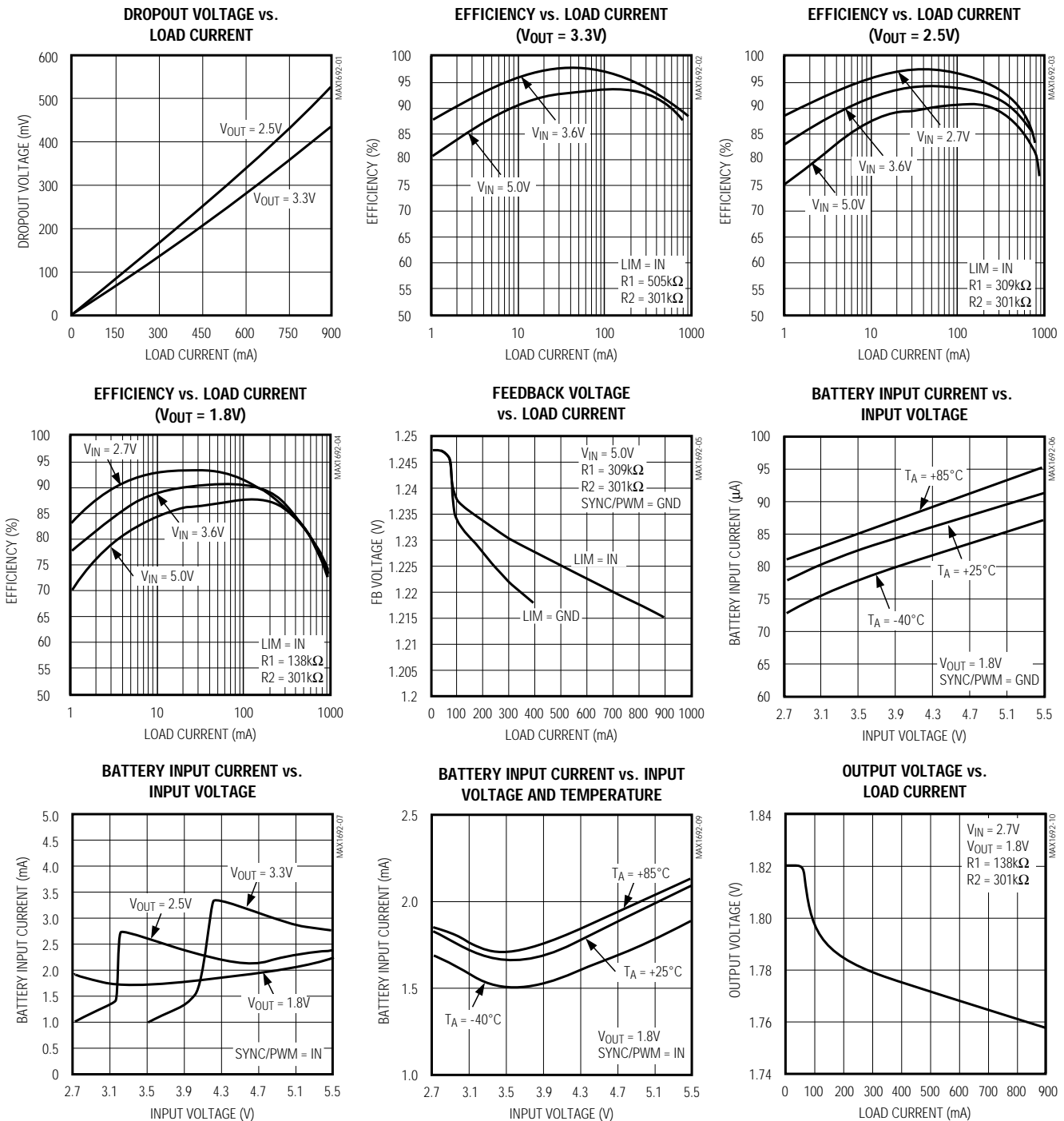

Low-Noise, 5.5V-Input, PWM Step-Down Regulator

MAX1692

Typical Operating Characteristics (continued)

(SYNC/PWM = GND, $T_A = +25^\circ\text{C}$, unless otherwise noted.)

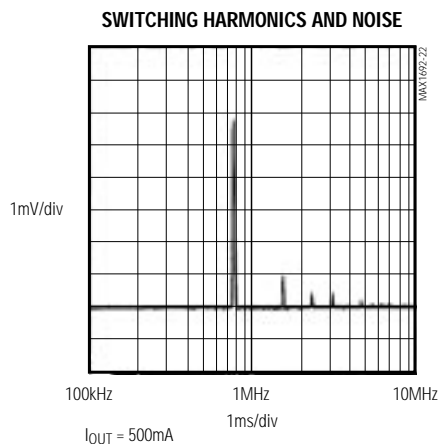
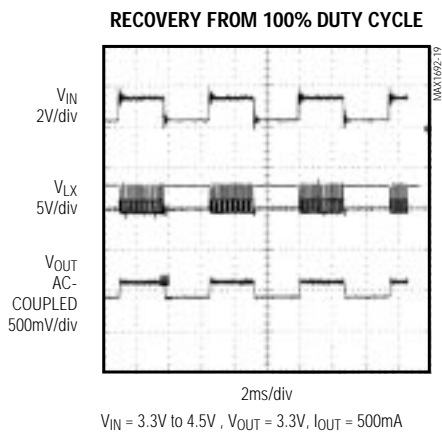
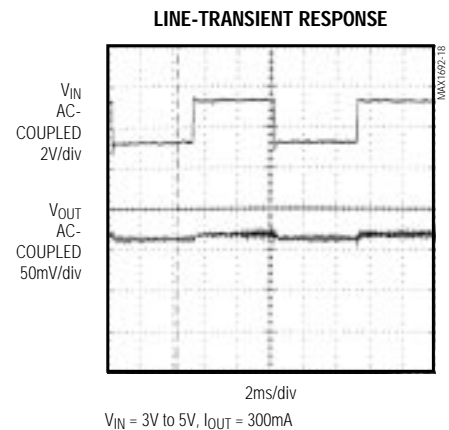
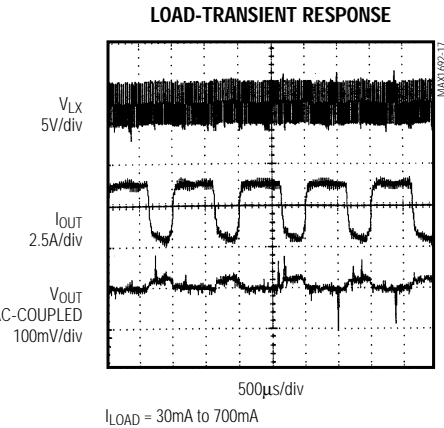
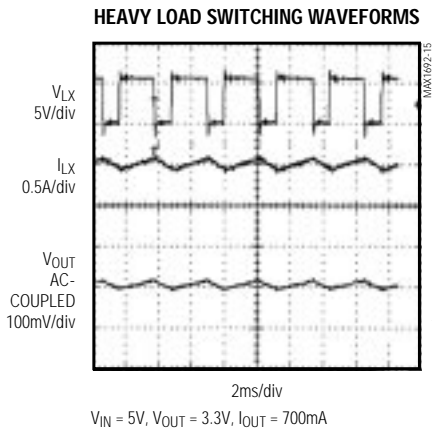
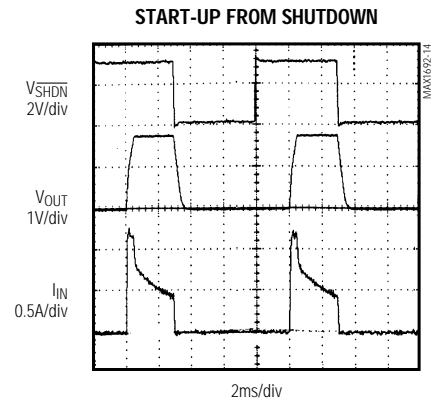
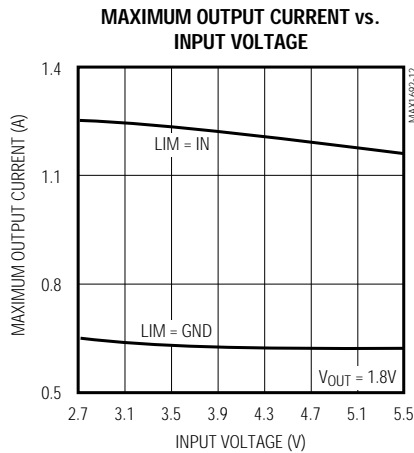
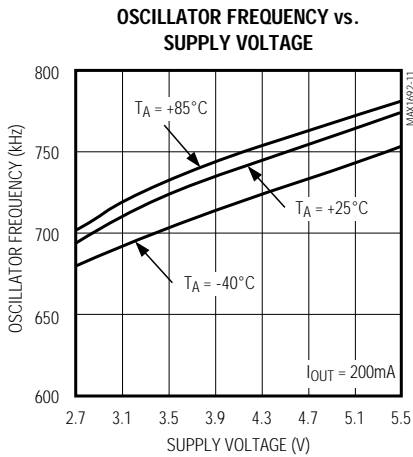

Low-Noise, 5.5V-Input, PWM Step-Down Regulator

Pin Description

PIN	NAME	FUNCTION
1	IN	Supply Voltage Input. Input range from +2.7V to +5.5V. Bypass with a 10 μ F capacitor.
2	BP	Supply Bypass Pin. Internally connected to IN. Bypass with a 0.1 μ F capacitor. Do not connect to an external power source other than IN.
3	GND	Ground
4	REF	1.25V, 1.2% Reference Output. Capable of delivering 50 μ A to external loads. Bypass with a 0.22 μ F capacitor to GND.
5	FB	Feedback Input
6	LIM	Current-Limit Select Input. Connect LIM to GND for 0.6A current limit or LIM to IN for 1.2A current limit.
7	SYNC/ PWM	Oscillator Sync and Low-Noise, Mode-Control Input. SYNC/PWM = IN (Forced PWM Mode) SYNC/PWM = GND (PWM/PFM Mode) An external clock signal connected to this pin allows for LX switching synchronization.
8	$\overline{\text{SHDN}}$	Active-Low, Shutdown-Control Input. Reduces quiescent current to 0.1 μ A. In shutdown, output becomes high impedance.
9	LX	Inductor Connection to the Drains of the Internal Power MOSFETs
10	PGND	Power Ground

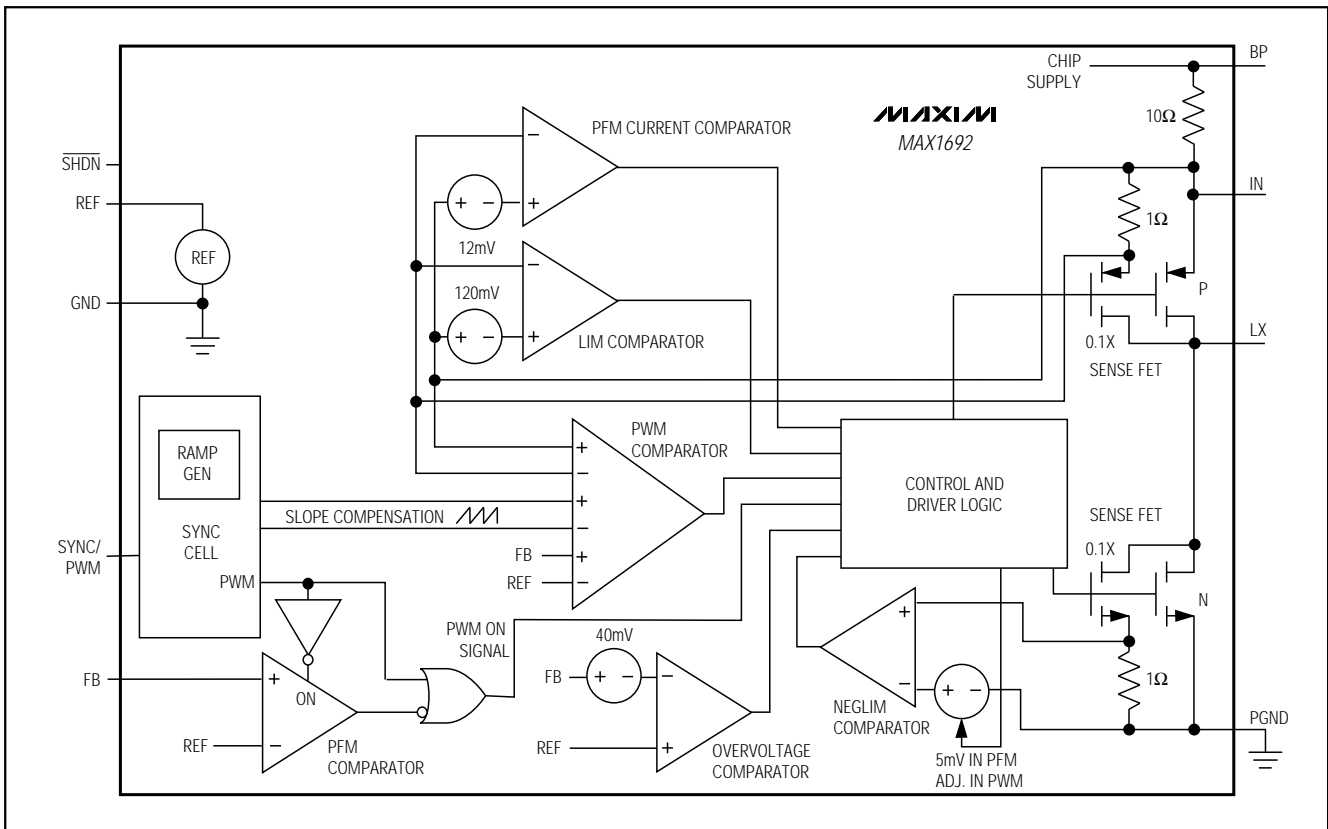

Figure 1. Simplified Functional Diagram

Low-Noise, 5.5V-Input, PWM Step-Down Regulator

MAX1692

Detailed Description

The MAX1692 step-down, pulse-width-modulated (PWM), DC-DC converter has an adjustable output range from 1.25V to the input voltage. An internal synchronous rectifier improves efficiency and eliminates an external Schottky diode. Fixed-frequency operation enables easy post-filtering, thereby providing excellent noise characteristics. As a result, the MAX1692 is an ideal choice for many small wireless systems.

The MAX1692 accepts inputs as low as +2.7V while still delivering 600mA. The MAX1692 can operate in four modes to optimize performance. A forced (PWM) mode switches at a fixed frequency, regardless of load, for easy post-filtering. A synchronizable PWM mode uses an external clock to minimize harmonics. A PWM/PFM mode extends battery life by operating in PWM mode under heavy loads and PFM mode under light loads for reduced power consumption. Shutdown mode reduces quiescent current to 0.1 μ A.

PWM Control Scheme

The MAX1692 uses a slope-compensated, current-mode PWM controller capable of achieving 100% duty cycle. The device uses an oscillator-triggered, minimum on-time, current-mode control scheme. The minimum on-time is approximately 150ns unless in dropout. The maximum on-time is approximately $2/f_{OSC}$, allowing operation to 100% duty cycle. Current-mode feedback provides cycle-by-cycle current limiting for superior load- and line-response and protection of the internal MOSFET and rectifier.

At each falling edge of the internal oscillator, the SYNC cell sends a PWM ON signal to the control and drive logic, turning on the internal P-channel MOSFET (main switch) (Figure 1). This allows current to ramp up through the inductor (Figure 2) to the load, and stores energy in a magnetic field. The switch remains on until either the current-limit (LIM) comparator is tripped or the PWM comparator signals that the output is in regulation. When the switch turns off during the second half of each cycle, the inductor's magnetic field collapses, releasing the stored energy and forcing current through the N-channel synchronous rectifier to the output-filter capacitor and load. The output-filter capacitor stores charge when the inductor current is high and releases it when the inductor current is low, thus smoothing the voltage across the load.

During normal operation, the MAX1692 regulates output voltage by switching at a constant frequency and then modulating the power transferred to the load each cycle using the PWM comparator. A multi-input comparator sums three weighted differential signals: the

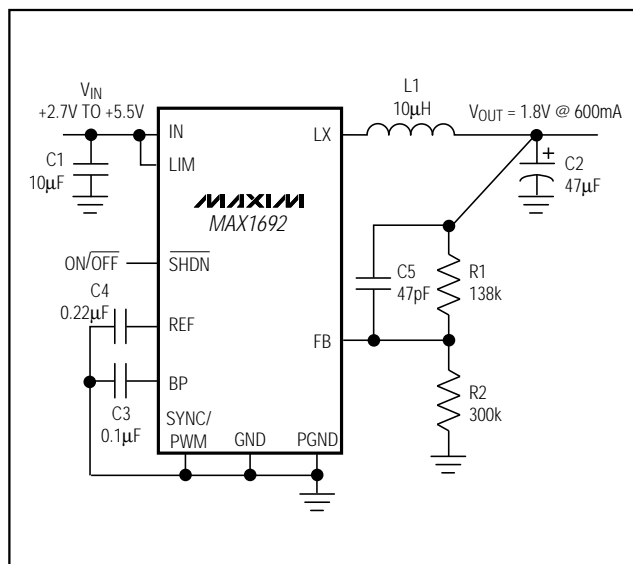

Figure 2. Standard Application Circuit

output voltage with respect to the reference, the main switch current sense, and the slope-compensation ramp. It modulates output power by adjusting the inductor-peak current during the first half of each cycle, based on the output-error voltage. The MAX1692's loop gain is relatively low to enable the use of a small, low-valued output-filter capacitor. The resulting load regulation is 1.3% (typ) at 0 to 600mA.

100% Duty-Cycle Operation

The maximum on-time can exceed one internal oscillator cycle, which permits operation up to 100% duty cycle. As the input voltage drops, the duty cycle increases until the P-channel MOSFET is held on continuously. Dropout voltage in 100% duty cycle is the output current multiplied by the on-resistance of the internal switch and inductor, around 280mV ($I_{OUT} = 600mA$). In PWM mode, subharmonic oscillation can occur near dropout but subharmonic voltage ripple is small, since the ripple current is low.

Synchronous Rectification

An N-channel, synchronous-rectifier improves efficiency during the second half of each cycle (off time). When the inductor current ramps below the threshold set by the NEGLIM comparator (Figure 1) or when the PWM reaches the end of the oscillator period, the synchronous rectifier turns off. This keeps excess current from flowing backward through the inductor, from the output-filter capacitor to GND, or through the switch and synchronous rectifier to GND. During PWM operation, the NEGLIM threshold adjusts to permit small

Low-Noise, 5.5V-Input, PWM Step-Down Regulator

amounts of reverse current to flow from the output during light loads. This allows regulation with a constant-switching frequency and eliminates minimum load requirements. The NEGLIM comparator threshold is 50mA if $V_{FB} < 1.25V$, and decreases as V_{FB} exceeds 1.25V to prevent the output from rising. The NEGLIM threshold in PFM mode is fixed at 50mA. (See *Forced PWM and PWM/PFM Operation* section.)

Forced PWM and PWM/PFM Operation

Connect SYNC/PWM to IN for normal forced PWM operation. Forced PWM operation is desirable in sensitive RF and data-acquisition applications, to ensure that switching-noise harmonics do not interfere with sensitive IF and data-sampling frequencies. A minimum load is not required during forced PWM operation, since the synchronous rectifier passes reverse-inductor current as needed to allow constant-frequency operation with no load. Forced PWM operation uses higher supply current with no load (2mA typ).

Connecting SYNC/PWM to GND enables PWM/PFM operation. This proprietary control scheme overrides PWM mode and places the MAX1692 in PFM mode at light loads to improve efficiency and reduce quiescent current to 85 μ A. With PWM/PFM enabled, the MAX1692 initiates pulse-skipping PFM operation when the peak inductor current drops below 120mA. During PFM operation, the MAX1692 switches only as needed to service the load, reducing the switching frequency and associated losses in the internal switch, the synchronous rectifier, and the external inductor.

During PFM mode, a switching cycle initiates when the PFM comparator senses that the output voltage has dropped too low. The P-channel MOSFET switch turns on and conducts current to the output-filter capacitor and load until the inductor current reaches the PFM peak current limit (120mA). Then the switch turns off and the magnetic field in the inductor collapses, forcing current through the synchronous rectifier to the output filter capacitor and load. Then the MAX1692 waits until the PFM comparator senses a low output voltage again.

The PFM current comparator controls both entry into PWM mode and the peak switching current during PFM mode. Consequently, some jitter is normal during transition from PFM to PWM modes with loads around 100mA, and it has no adverse impact on regulation.

Output ripple is higher during PFM operation. A larger output-filter capacitor can be used to minimize ripple.

SYNC Input and Frequency Control

The MAX1692's internal oscillator is set for a fixed-switching frequency of 750kHz or can be synchronized to an external clock. Connect SYNC to IN for forced-PWM operation. Do not leave SYNC/PWM unconnected. Connecting SYNC/PWM to GND enables PWM/PFM operation to reduce supply current at light loads. SYNC/PWM is a negative-edge triggered input that allows synchronization to an external frequency ranging between 500kHz and 1000kHz. When SYNC/PWM is clocked by an external signal, the converter operates in forced PWM mode. If SYNC is low or high for more than 100 μ s, the oscillator defaults to 750kHz.

Shutdown Mode

Connecting $\overline{\text{SHDN}}$ to GND places the MAX1692 in shutdown mode. In shutdown, the reference, control circuitry, internal switching MOSFET, and the synchronous rectifier turn off and the output falls to 0V. Connect $\overline{\text{SHDN}}$ to IN for normal operation.

Current-Sense Comparators

The MAX1692 uses several internal current-sense comparators. In PWM operation, the PWM comparator sets the cycle-by-cycle current limit (Figure 1) and provides improved load and line response, allowing tighter specification of the inductor-saturation current limit to reduce inductor cost. A second 120mA current-sense comparator used across the P-channel switch controls entry into PFM mode. A third current-sense comparator monitors current through the internal N-channel MOSFET to set the NEGLIM threshold and determine when to turn off the synchronous rectifier. A fourth comparator (LIM) used at the P-channel MOSFET switch detects overcurrent. This protects the system, external components, and internal MOSFETs under overload conditions.

Applications Information

Output Voltage Selection

Select an output voltage between 1.25V and V_{IN} by connecting FB to a resistor-divider between the output and GND (Figure 2). Select feedback resistor R2 in the 5k Ω to 500k Ω range. R1 is then given by:

$$R1 = R2 [(V_{OUT} / V_{FB}) - 1]$$

where $V_{FB} = 1.232V$ (See Note 2 of the *Electrical Characteristics*). Add a small ceramic capacitor (C5) around 47pF to 100pF in parallel with R1 to compensate for stray capacitance at the FB pin and output capacitor equivalent series resistance (ESR).

Low-Noise, 5.5V-Input, PWM Step-Down Regulator

Capacitor Selection

Choose input- and output-filter capacitors to service inductor currents with acceptable voltage ripple. The input-filter capacitor also reduces peak currents and noise at the voltage source. In addition, connect a low-ESR bulk capacitor ($>10\mu\text{F}$ suggested) to the input. Select this bulk capacitor to meet the input ripple requirements and voltage rating, rather than capacitor size. Use the following equation to calculate the maximum RMS input current:

$$I_{\text{RMS}} = I_{\text{OUT}}[V_{\text{OUT}}(V_{\text{IN}} - V_{\text{OUT}})]^{1/2} \cdot V_{\text{IN}}$$

When selecting an output capacitor, consider the output-ripple voltage and approximate it as the product of the ripple current and the ESR of the output capacitor.

$$V_{\text{RIPPLE}} = \frac{[V_{\text{OUT}}(V_{\text{IN}} - V_{\text{OUT}})]}{[2 \cdot f_{\text{OSC}}(L)(V_{\text{IN}})] \cdot \text{ESR}_{\text{C2}}}$$

where ESR_{C2} is the equivalent-series resistance of the output capacitor.

The MAX1692's loop gain is relatively low, enabling the use of small, low-value output filter capacitors. Higher values provide improved output ripple and transient response. Lower oscillator frequencies require a larger-value output capacitor. When PWM/PFM is used, verify capacitor selection with light loads during PFM operation, since output ripple is higher under these conditions. Low-ESR capacitors are recommended.

Capacitor ESR is a major contributor to output ripple (usually more than 60%). Ordinary aluminum-electrolytic capacitors have high ESR and should be avoided. Low-ESR aluminum-electrolytic capacitors are acceptable and relatively inexpensive. Low-ESR tantalum capacitors are better and provide a compact solution for space-constrained surface-mount designs. Do not exceed the ripple-current ratings of tantalum capacitors. Ceramic capacitors have the lowest ESR overall, and OS-CON™ capacitors have the lowest ESR of the high-value electrolytic types.

It is generally not necessary to use ceramic or OS-CON capacitors for the MAX1692; consider them only in very compact, high-reliability, or wide-temperature applications where the expense is justified. When using very-low-ESR capacitors, such as ceramic or OS-CON, check for stability while examining load-transient response. The output capacitor is determined by ensuring that the minimum capacitance value and maximum

ESR values are met:

$$C2 > 2V_{\text{REF}}(1 + V_{\text{OUT}}/V_{\text{IN}(\text{MIN})}) / (V_{\text{OUT}} \cdot R_{\text{SENSE}} \cdot f_{\text{OSC}})$$

$$\text{RESR} < (R_{\text{SENSE}})(V_{\text{OUT}}) / (V_{\text{REF}})$$

where $C2$ is the output filter capacitor, V_{REF} is the internal reference voltage of 1.25V, $V_{\text{IN}(\text{min})}$ is the minimum input voltage (2.7V), R_{SENSE} is the internal sense resistance of 0.1Ω , and f_{OSC} is the internal oscillator frequency (typically 750kHz). These equations provide the minimum requirements. The value of $C2$ may need to be increased for operation at duty-cycle extremes.

Tables 1 and 2 provide recommended inductor and capacitor sizes at various external sync frequencies. Table 3 lists suppliers for the various components used with the MAX1692.

Standard Application Circuits

Figures 2 and 3 are standard application circuits optimized for power and board space respectively. The circuit of Figure 2 is the most general of the two, and generates 1.8V at 600mA.

The circuit of Figure 3 is optimized for smallest overall size. Cellular phones are using low voltage for base-band logic and have critical area and height restrictions. This circuit operates from a single Li-ion battery (2.9V to 4.5V) and delivers up to 200mA at 1.8V. It uses small ceramic capacitors at the input and output and a tiny chip inductor such as the NLC322522T series from TDK. With the MAX1692 in a 10-pin μMAX package, the entire circuit can fit in only 60mm^2 and have less than 2.4mm height.

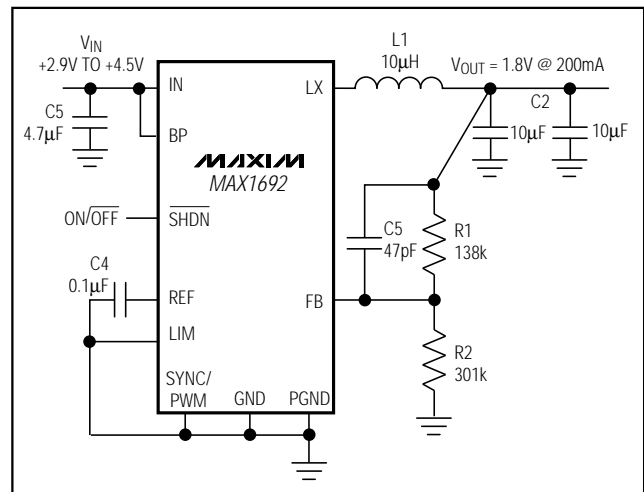

Figure 3. Miniaturized 200mA Output Circuit Fits in 60mm^2

OS-CON is a trademark of Sanyo Corp.

Low-Noise, 5.5V-Input, PWM Step-Down Regulator

Bypass Considerations

Bypass IN and OUT to PGND with 10 μ F and 47 μ F, respectively. Bypass BP and REF to GND with 0.1 μ F and 0.22 μ F, respectively. Locate the bypass capacitors as close as possible to their respective pins to minimize noise coupling. For optimum performance, place input and output capacitors as close to the device as feasible (see *Capacitor Selection* section).

PC Board Layout and Routing

High switching frequencies and large peak currents make PC board layout a very important part of design. Good design minimizes excessive EMI on the feedback paths and voltage gradients in the ground plane, both

of which can result in instability or regulation errors. Connect the inductor, input filter capacitor, and output filter capacitor as close together as possible, and keep their traces short, direct, and wide. Connect their ground pins at a single common node in a star-ground configuration. The external voltage-feedback network should be very close to the FB pin, within 0.2in (5mm). Keep noisy traces, such as from the LX pin, away from the voltage-feedback network; also keep them separate, using grounded copper. Connect GND and PGND at the highest quality ground. The MAX1692 evaluation kit manual illustrates an example PC board layout and routing scheme.

Table 1. Suggested Inductors

OUTPUT VOLTAGE RANGE (V)	INDUCTOR L VALUE (μ H)	SUGGESTED INDUCTORS
1.25 to 2.5	10	Sumida CD43-100 Coilcraft D01608C-103 Sumida CD54-100 TDK NLC322522-100T
2.5 to 4.0	22	Sumida CD43-220 Sumida CD54-220
4.0 to 5.5	33	Sumida CD43-330 Sumida CD54-330

Table 2. Suggested Capacitors

MANUFACTURER PART NUMBER	TYPE	ESR (m Ω)
AVX TPSD476M016R0150	Tantalum	150
Sanyo 6TPA47M	Poscap	100
Sprague 594D686X9010C2T	Tantalum	95
Taiyo Yuden JMK325BJ106MN	Ceramic	50

Table 3. Component Suppliers

COMPANY	PHONE	FAX
AVX	843-946-0238	843-626-3123
Coilcraft	847-639-6400	847-639-1469
Coiltronics	561-241-7876	561-241-9339
Kemet	408-986-0424	408-986-1442
Nihon	USA 805- 867-2555 Japan 81-3-3494-7411	805- 867-2698 81-3-3494-7414
Sanyo	USA 619-661-6835 Japan 81-7-2070-6306	619-661-1055 81-7-2070-1174
Sprague	603-224-1961	603- 224-1430
Sumida	USA 847-956-0666 Japan 81-3-3607-5111	847- 956-0702 81-3-3607-5144
Taiyo Yuden	408-573-4150	408-573-4159
TDK	847-390-4373	847-390-4428

Low-Noise, 5.5V-Input, PWM Step-Down Regulator

Chip Information

TRANSISTOR COUNT: 1462

Package Information

MAX1692

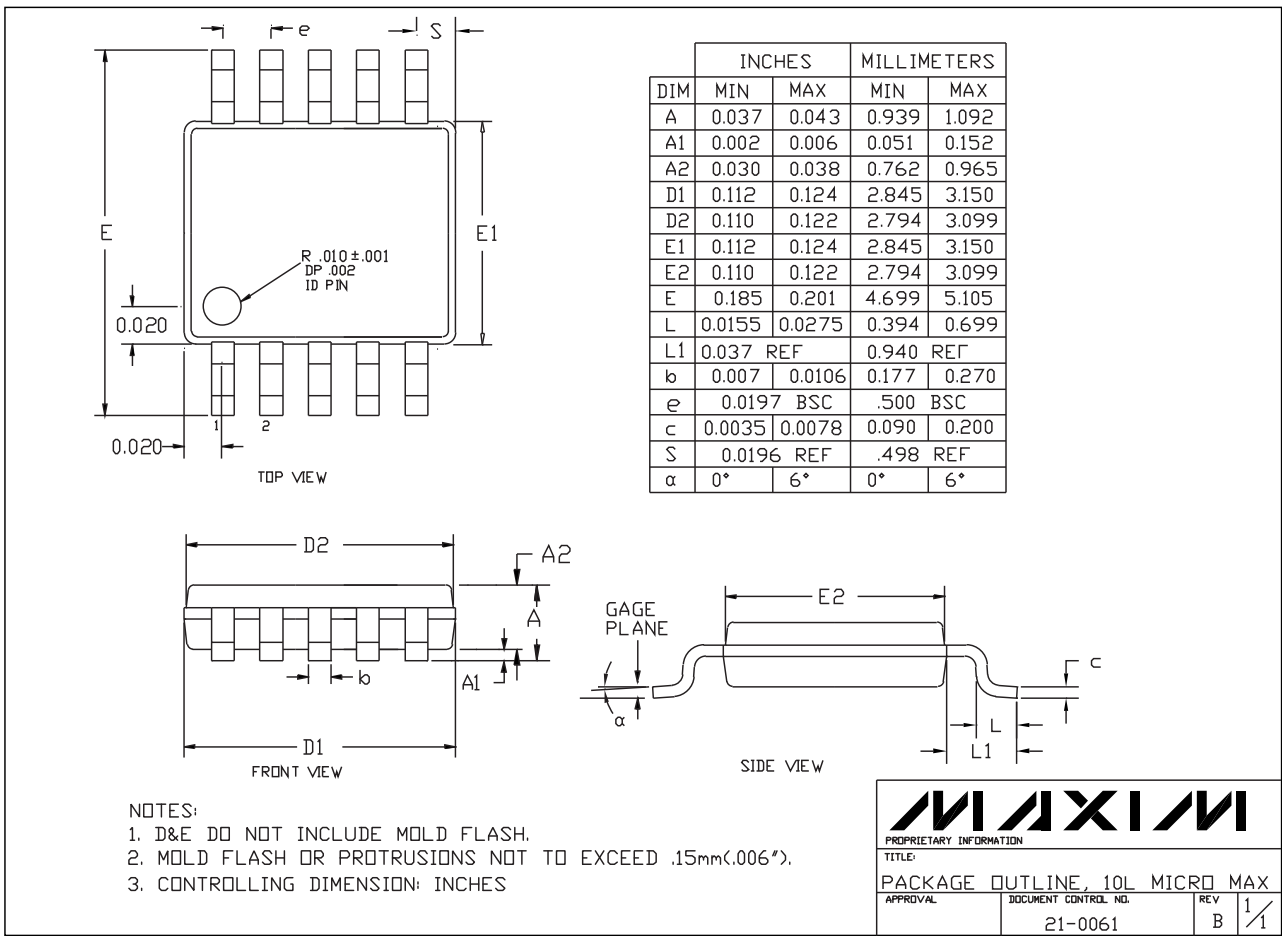

10LUMAXB.EPS

Low-Noise, 5.5V-Input, PWM Step-Down Regulator

NOTES

Maxim cannot assume responsibility for use of any circuitry other than circuitry entirely embodied in a Maxim product. No circuit patent licenses are implied. Maxim reserves the right to change the circuitry and specifications without notice at any time.

12 _____ Maxim Integrated Products, 120 San Gabriel Drive, Sunnyvale, CA 94086 408-737-7600